



FERRO
FER
STEEL
HIERRO

Art. 482-483



Art. 483

Art. 482

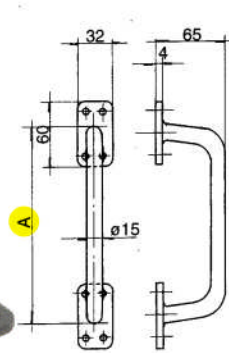

Art. 482
Tipo diritto
Type droit
Right model
Tipo recto

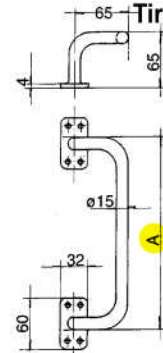

Art. 483
Tipo piegato
Type plié
bended model
Tipo curvos

Maniglie per portoni scorrevoli

Poignée pour portails coulissants
Handles for sliding gates
Tirador para cancelas correderas

Art.	482	
A mm	180	230
CODICE ART.	482180	482230
N° Pcs	10	10
Kg.	4,800	5,410

In acciaio verniciato nero
Acier verni noir
Steel lackered black
en acero pintado negro

Art.	483	
A mm	180	230
CODICE ART.	483180	483230
N° Pcs	10	10
Kg.	5,900	6,270

Maniglioni per portoni scorrevoli in tubolare

Art. 490-491



Art. 491

Art. 490

In acciaio verniciato nero - Acier verni noir
Steel lackered black- En acero pintado negro

Poignées pour portails
Handles for gates
Tirador para cancelas correderas

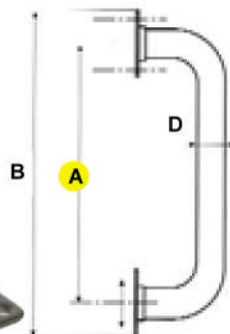

Art. 490
Tipo diritto
Type droit
Right model
Tipo recto

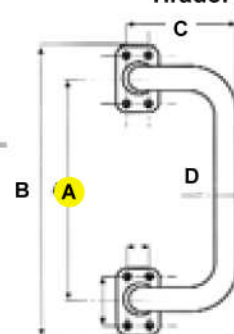

Art. 491
Tipo piegato
Type plié
bended model
Tipo curvos

Art.	490	
A mm	180	280
B mm	230	345
D mm	20	28
COD. 490	490180	490280
N° Pcs	10	10
Kg.		

Art.	491	
A mm	180	280
COD. 483	491180	491280
N° Pcs	10	8
Kg.	4,400	6,950

Maniglie da incassare per portoni scorrevoli

Art. 485/P-485/G

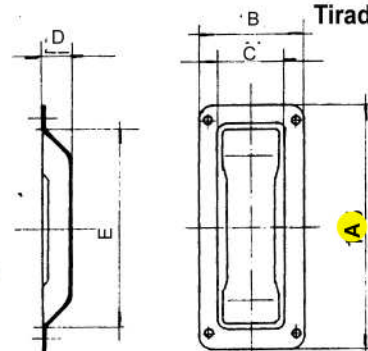

in acciaio zincato
acier galvanizé
galvanized steel
acero cingado

Art.	485/P	485/G
A mm	175	200
B mm	76	90
C mm	41	50
D mm	22	22
E mm	145	160
CODICE ART.	485P	485G
N° Pcs	40	20
Kg.	8,000	4,200

Art. 485/P
Tipo piccolo
Type petit
Small size
Tipo pequeno

Art. 485/G
Tipo grande
Type grand
Big size
Tipo grande

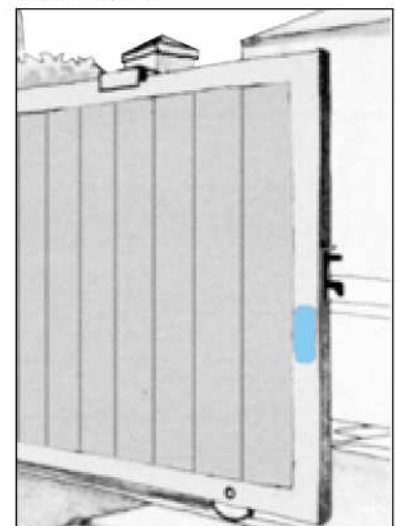

Martellina regolabile con vite per basculanti

Art. 437M-437/C



Art. 437M
finitura verniciata nera
finition laqué noir
black lackered
pintado negro



Poignée réglable avec vis pour basculantes
Regulating handle with screw for garage doors
Manilla regulable con tornillos para basculante

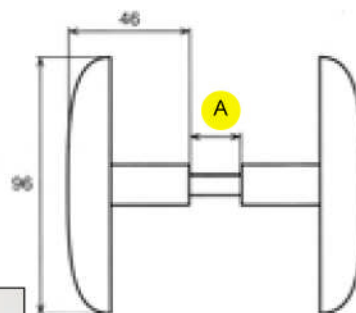

A mm	25+38
COD. 437M	437M
COD. 437/C	437C
N° Pcs	15
Kg.	3,270

Misura su richiesta
sur demande
on request

A mm
35 + 50
45 + 60
55 + 70

Art. 437/C
finitura cromata
finition chromé
chrome plated
cromada

Maniglie per porte metalliche con vite

Art. 435-436



Art. 435
verniciate nere
verni noir
black painted
pintado negro

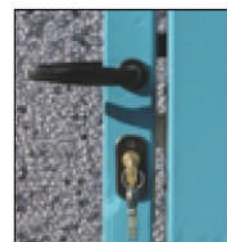
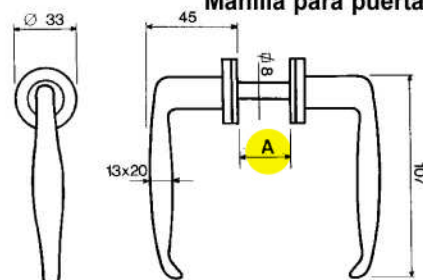

Poignées pour portes métalliques avec vis
Handles for metallic doors with screw
Manilla para puertas metalicas con tornillo

Misure	STANDARD	SU RICHIESTA SUR DEMANDE ON REQUEST			
A mm	25+38	35+50	45+60	55+70	
COD. 435	435025	435035	435045	435055	
COD. 436	436025	436035	436045	436055	
N° Pcs	15	15	15	15	
Kg.	3,400	3,450	3,500	3,500	

Art. 436
cromate
chromé
chromed
cromada

Maniglie per porte metalliche regolabili con grano

Art. 535



verniciate nere
verni noir
black painted
pintado negro

Poignées pour portes métalliques réglables avec grain de fixation
Regulating handles for doors with screwed pin
Manilla para puertas metalicas regulable

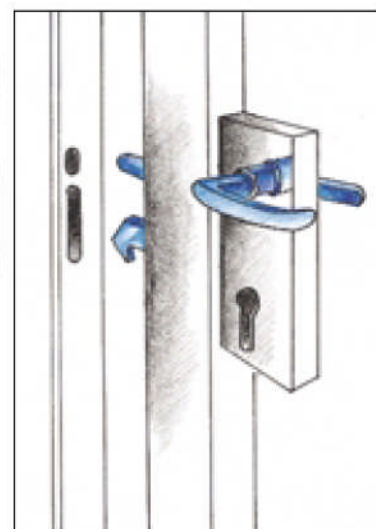
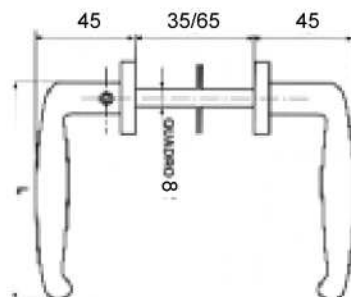

Art.	535
CODICE ART.	535
N° Pcs	10
Kg.	1,650



FERRO
FER
STEEL
HIERRO

Art. 536



New

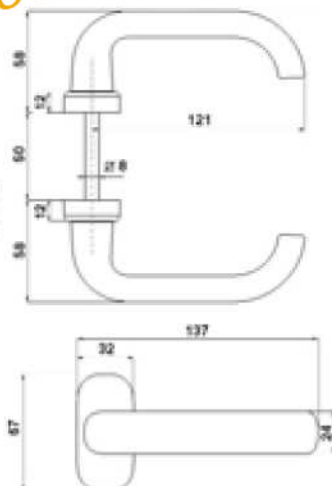

Maniglia in resina con molla

Poignée en plastique avec ressort
Plastic handle with spring
Manilla en plastico con muelle

Art. 536/N
Colore nero
couleur noir
black colour
pintado negro

Art. 536/B
Colore bianco
couleur blanc
white colour
pintado blanco

Art.	536
COD. 536/N	536N
COD. 536/B	536B
N° Pcs	10
Kg.	4,500

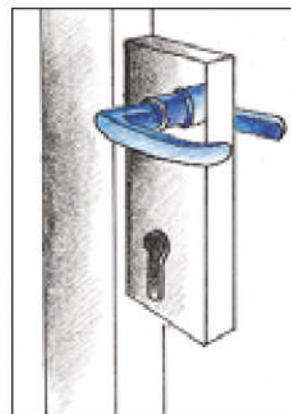

Art. 534

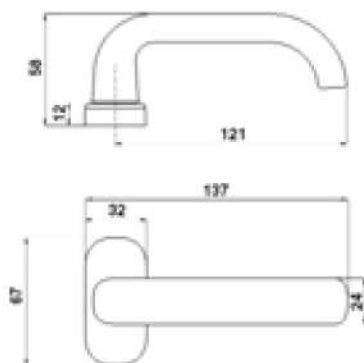

Maniglia in resina per persiana

Poignée en plastique pour persiennes
Plastic handle for shutters
Manilla en plastico por ventanas

Colore nero
couleur noir
black colour
pintado negro

Art.	534
CODICE ART.	534
N° Pcs	20
Kg.	1,800

Art. 434

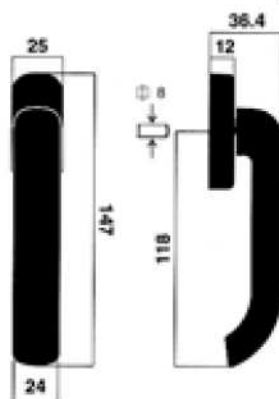

Martellina in resina per persiane - Tipo basso

Poignée en plastique pour persiennes - Type court
Plastic handle for shutters - Short model
Manilla en plastico por ventanas - Tipo curto

colore nero
couleur noir
black colour
pintado negro

Art.	434
CODICE ART.	434
N° Pcs	10
Kg.	1,100

Art. 537

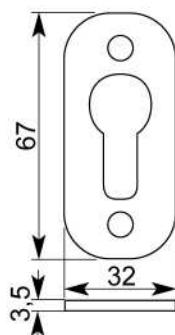

Copricilindro

Couverture pour cylindre
Plastic cover for cylinder
Cubierta en plastico por cilindro

colore nero
couleur noir
black colour
pintado negro

Art.	537
CODICE ART.	537
N° Pcs	
Kg.	

FERRO

Serratura a gancio per cancelli scorrevoli

Art. 447-447/A

Serrure pour portail coulissant
Lock for sliding gates
Cerradura pico loro para cancela

Art. 447/A Art. 447

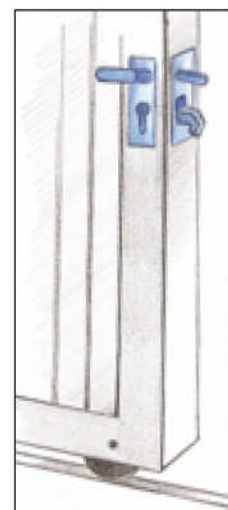
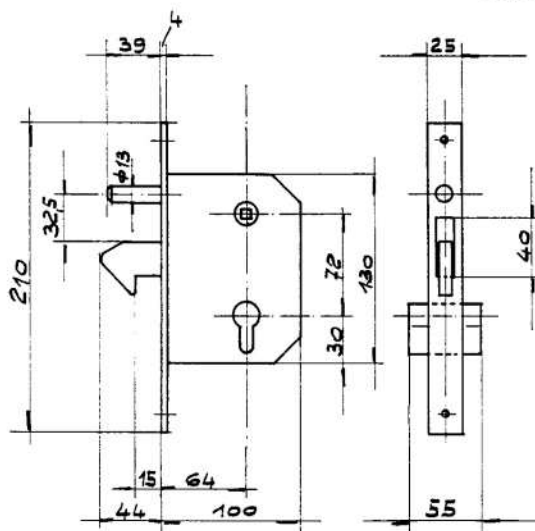

Art. 447
acciaio zincato
acier galvanizé
galvanized steel
hierro cingado

Art. 447/A
contropiastra per serrature
gache pour serrure
staple for locks
controplaca para cerradura

Art.	447	447/A
CODICE ART.	447	447A
N° Pcs	1	1
Kg.	1,260	0,100



Serratura a gancio per cancelli - tipo piccolo

Art. 447/P

Serrure a crochet pour portail - type petit
Hook lock for gates - small model
Cerradura pico loro - tipo pequeno

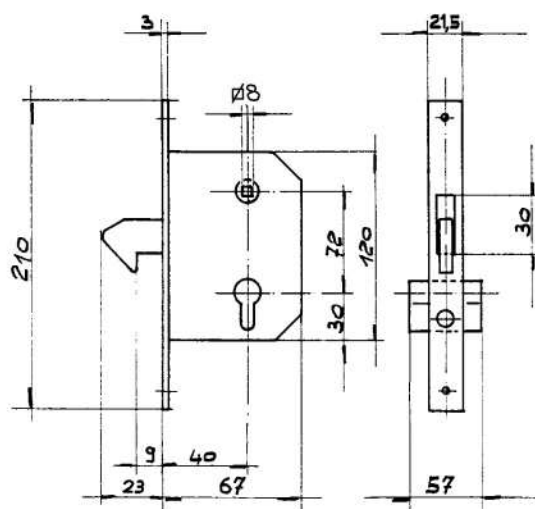

Acciaio tropicalizzato
Acier bichromaté
Yellow galvanized steel
hierro bicromatado

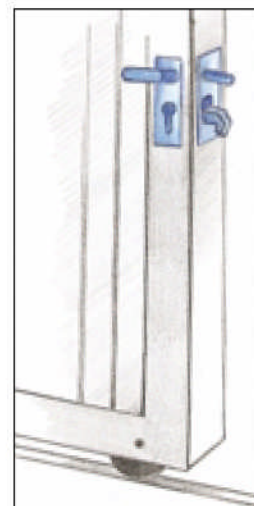

Art.	447/P
CODICE ART.	447P
N° Pcs	1
Kg.	0,720

Completo di n°3 chiavi e contropiastra
Complet avec 3 clés et contreplaque
Completo with 3 keys and staple
Completo 3 llaves e controplaca



FERRO
FER
STEEL
HIERRO

Serratura a gancio con perno - tipo piccolo

Art. 447/PB-447/S



Serrure a crochet avec pueute - type petit
Hook lock with pin - small model
Cerradura pico loro con pernio - tipo pequeno

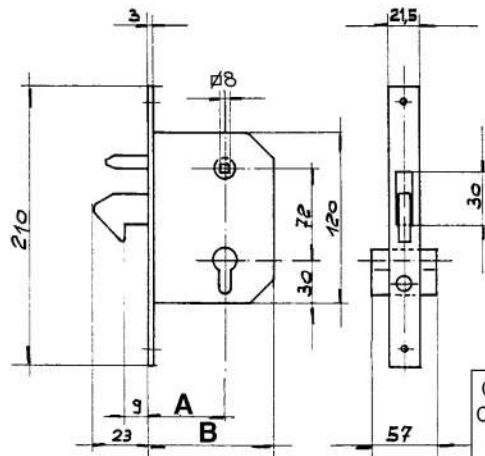

Acciaio tropicalizzato
Acier bichromaté
Yellow galvanized steel
hierro bicromatado

Art.	447/PB	447/S
A mm	40	30
B mm	67	57
CODICE ART.	447PB	447S
N° Pcs	1	1
Kg.	0,720	0,650

Completo di cilindro - 3 chiavi e contropiastra
Complet avec cylindre - 3 clés et contreplaque
Completo with cylinder - 3 keys and staple
Completo cilindro - 3 llaves e controplaca

Serratura doppio gancio rientrante per cancelli motorizzati

Art. 2570



Serrure a double crochet rentrant pour portail coulissant motorisés
Double re-entering hook Locks for motor sliding gates
Cerradura pico loro con doble gancho para cancela automatica

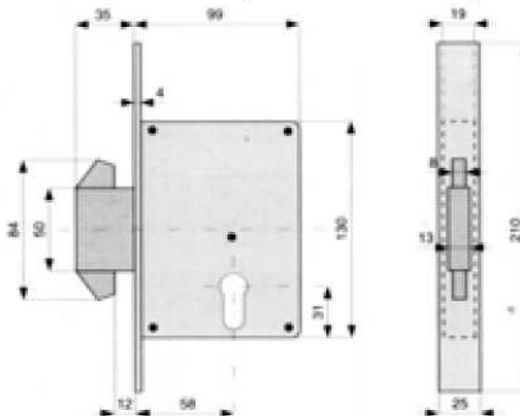

acciaio zincato - con cilindro mm 54
acier galvanizé - avec cylindre mm 54
galvanized steel - with cylinder mm 54
hierro cingado - con cilindro 54 mm

Art.	2570
CODICE ART.	2570
N° Pcs	1
Kg.	1,000

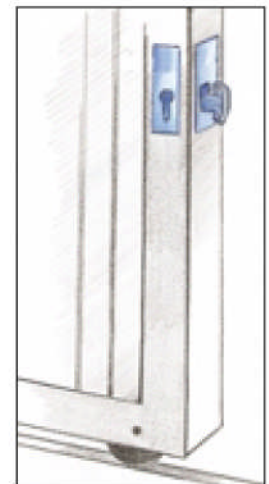

Art. 446



Scatole copriserrature a gancio

Couvertures pour serrure
Cover box for lock
Caja por cerradura pico loro

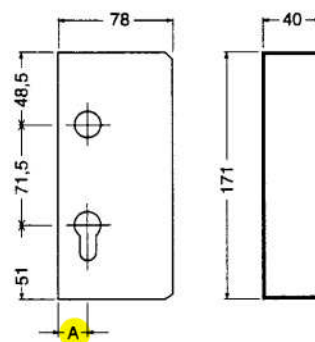

in acciaio zincato
en acier galvanizé
galvanized steel
hierro cingado

Per Art.	2570
A mm	20
CODICE ART.	446SF
N° Pcs	1
Kg.	0,600

PER TUBOLARE POUR TUBE FOR TUBE	40	50
A mm	20	10
CODICE ART.	446040	446050
N° Pcs	1	1
Kg.	0,600	0,600

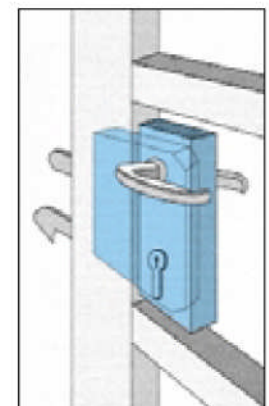

Serrature da infilare per profili in ferro

Serrure a mortaiser pour profils en fer
Mortice locks for steel profile

Cerradura para carpinteria metalica por tubos

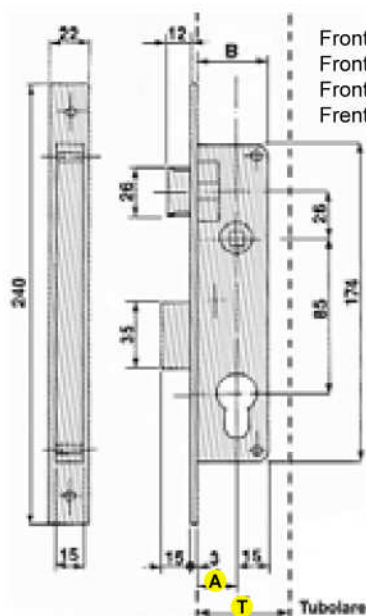

Frontale acciaio nickelato
Front acier nickelé
Front nickel plated steel
Frente hierro niquelado

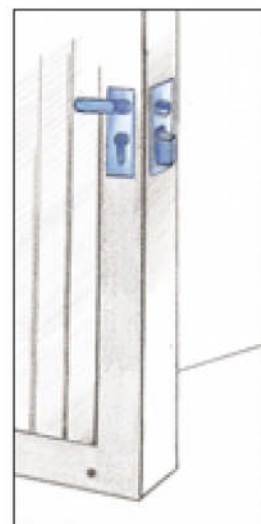

Complete di cilindro 54 mm - con 3 chiavi
Complet avec cylindre 54 mm - et 3 clés
Complet with cylinder 54 mm - and 3 keys
Completa cilindro 54 mm - con 3 llaves

PER TUBOLARE POUR TUBE FOR TUBE T	40x40	45x45	50x50
A mm	20	25	30
B mm	34	39	44
CODICE ART.	2500020	2500025	2500030
N° Pcs	1	1	1
Kg.	0,630	0,550	0,700

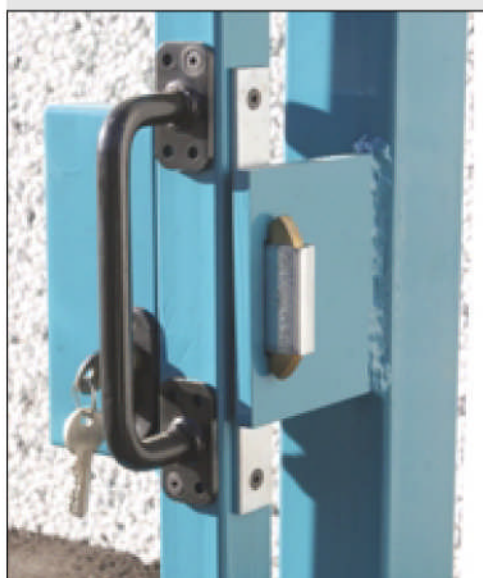

Serratura per cancelli metallici a battente - inossidabile

Art. 477

Serrure pour portails metalliques battants inoxydable
Locks for metallic gates rustproof
Cerradura para cancela metalica - inox

Serratura regolabile per profili quadri o tondi o rettangolari da mm 40/50/60 - completa di maniglia e cilindro con 3 chiavi - scrocco reversibile

Serrure réglable pour profils carrés ou ronds ou rectangulaires de mm 40/50/60 - Complete avec poignée et cylindre avec 3 clés - reversible

Locks for square or round or rectangular profile adjustable for mm 40/50/60 - Complet with handle and cylinder with 3 keys - reversible

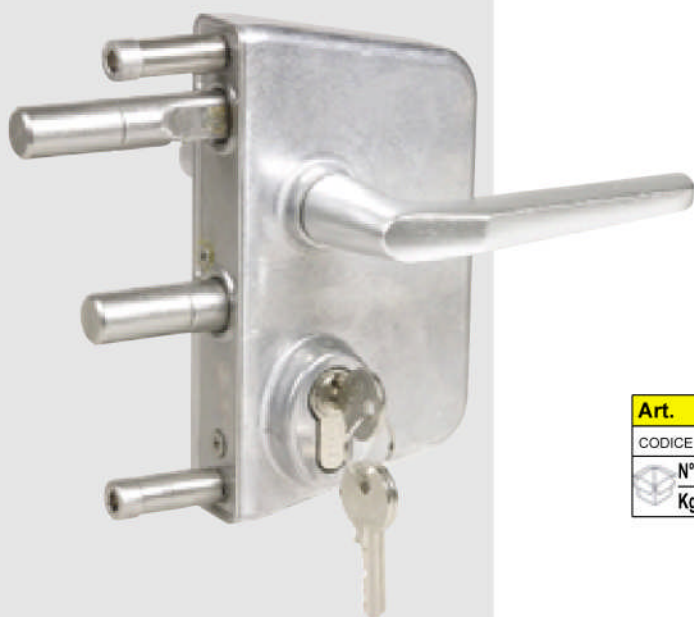

Art.	477
CODICE ART.	477
N° Pcs	1
Kg.	1,300

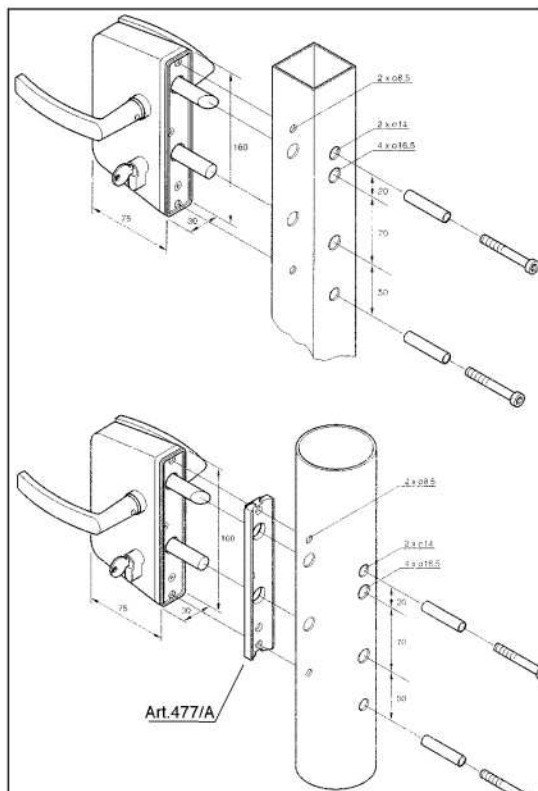
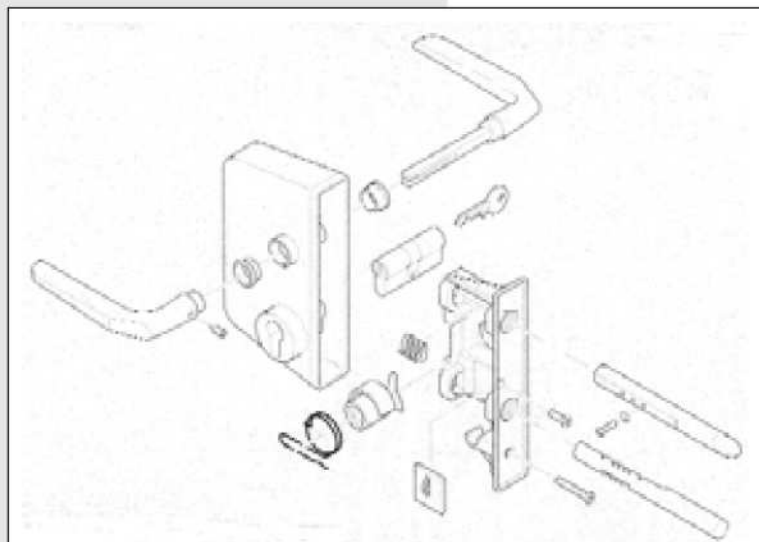

Incontri e piastra per serrature Art. 447

Art. 477/A-478-478/A

Gaches et plaque pour serrure Art. 447
Staples end plate for locks Art. 447
Encuentro y placa para cerraduras Art. 447

477/A 478



Art. 477/A

piastra per montaggio serrature su tubo tondo
plaque pour montage sur tube rond
mounting plate for round pipes
placa por tubular redondo

Art. 478/A

incontri per serrature - per tondi
gaches pour serrure - pour rond
locks staples - for round
encuentro por tubular redondo

Art. 478

incontri per serrature - per quadri
gaches pour serrure - pour carré
locks staples - for square
encuentro por tubular cuadro

478/A



Art.	477/A	478	478/A
CODICE ART.	477A	478	478A
N° Pcs	1	1	1
Kg.			